



Atmospheric Reserve

Description

The atmospheric storage reserve is used to smooth out the availability of pure water to the humidifier. Peaks in water demand, for example draining the tank for service, can require more water than the reverse osmosis unit can supply instantaneously. The advantage of atmospheric reserve is the larger volume it can hold compared to pressurized reserve. The atmospheric tank is holding water without pressure. It requires an additional booster pump and pressure switch to supply the water to humidifiers or other equipment.



Model Specifications

Part Number	Nom. Size [GAL]	Act. Volume [GAL]	DIA. [in]	H [in]	Dry Weight [lb]	Service Weight [lb]
WS ATMR150	150	140	30	56	110	1450
WS ATMR200	200	150	30	70 1/2	130	1550
WS ATMR300	300	250	35	79	170	2430
WS ATMR500	500	400	48	70 1/2	230	3740

General Technical Specifications

Description	
Material	High Density Polyethylene
Maximum temperature	180°F (82°C)

Typical Layout

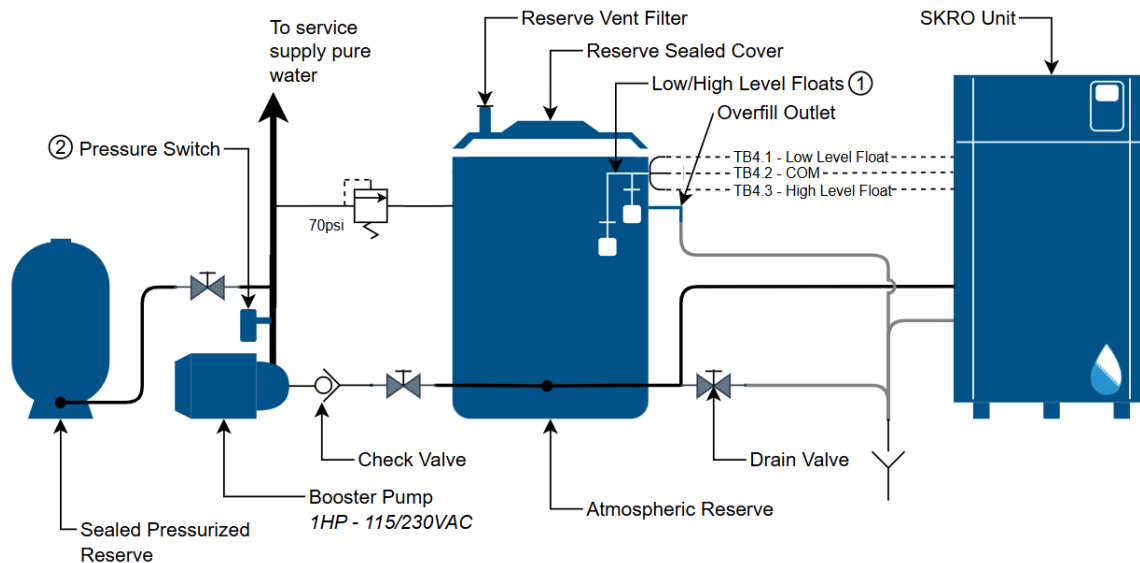



Accessories

Float Kit

WS ATMRFLOAT1	Float Kit 1 Position	<p>Float kit is essential for the SKRO to know the level of water in the atmospheric reserve. It is the signal to start and stop the treatment of water.</p> <p>A 3rd optional float can be wired to detect a critically low level. It can be used to protect the booster pump from starving of water.</p>
WS ATMRFLOAT2	Float Kit 2 Positions, High and Low	
WS ATMRFLOAT3	Float Kit 3 Positions, High, Low and Alarm	

Booster Pump

WS BSTRP10	Booster pump polymer body, 13.5GPM at 50psi; With motor 1HP 115/230V – 1ph; With pressure switch 30/50	<p>Booster pump is used to pressurize the water coming from the atmospheric reserve. It is necessary for general humidifiers and other appliances to have an inlet pressure to function properly.</p> <p>The pump comes with an activation switch when the network pressure falls below 30psi. It cuts off at 50psi.</p>
------------	--	--

Sealed Pressurized Reserve

WS PRSR015	15Gal. Pressurized Fiberglass Storage Tank	<p>A sealed pressurized reserved should be added after the booster pump to prevent cycling of the pump and provide water while the pump ramps up to nominal flow.</p> <p>The reserve shall be sized based on the equipment on the pure water network.</p>
WS PRSR020	20Gal. Pressurized Fiberglass Storage Tank	
WS PRSR040	40Gal. Pressurized Fiberglass Storage Tank	

UV Lamp

WS UVL01-CAN	1GPM Ultraviolet Treatment Lamp	<p>While the water from the reverse osmosis unit is free of any contaminant, since the reserve is not sealed, pure water can be contaminated from the outside. A UV lamp can be added before the pump to sterilize the stored water for sensitive applications.</p>
WS UVL04-CAN	4GPM Ultraviolet Treatment Lamp	
WS UVL05-CAN	5GPM Ultraviolet Treatment Lamp	
WS UVL09-CAN	9GPM Ultraviolet Treatment Lamp	
WS UVL18-CAN	18GPM Ultraviolet Treatment Lamp	